

# ICC-ES Evaluation Report

ESR-3782

Reissued June 2026

This report also contains:

- [FL Supplement w/ HVHZ](#)

This report remains under an active [continuous compliance program](#) through the end of May 2027

ICC-ES Evaluation Reports are not to be construed as representing aesthetics or any other attributes not specifically addressed, nor are they to be construed as an endorsement of the subject of the report or a recommendation for its use. There is no warranty by ICC Evaluation Service, LLC, express or implied, as to any finding or other matter in this report, or as to any product covered by the report.

Copyright © 2026 ICC Evaluation Service, LLC. All rights reserved.

<p><b>DIVISION: 03 00 00— CONCRETE</b></p> <p><b>Section: 03 16 00— Concrete Anchors</b></p> <p><b>DIVISION: 05 00 00— METALS</b></p> <p><b>Section: 05 05 19—Post- Installed Concrete Anchors</b></p>	<p><b>REPORT HOLDER:</b> <b>MKT FASTENING, LLC</b></p>	<p><b>EVALUATION SUBJECT:</b> <b>SRS+ ANCHOR IN UNCRACKED CONCRETE AND SRS ANCHOR IN CRACKED AND UNCRACKED CONCRETE (REDUNDANT APPL.)</b></p>	
--	--	---	---

## 1.0 EVALUATION SCOPE

### Compliance with the following codes:

- 2024, 2021, 2018, 2015 and 2012 [International Building Code® \(IBC\)](#)
- 2024, 2021, 2018, 2015 and 2012 [International Residential Code® \(IRC\)](#)

Main references of this report are for the 2024 IBC and IRC. See [Table 7](#) and [Table 8](#) for applicable sections of the code for previous IBC and IRC editions.

### Properties evaluated:

- Structural
- Nonstructural

## 2.0 USES

The MKT SRS+ Carbon Steel Wedge Anchor is used to resist static, wind and seismic (Seismic Design Categories A and B only) tension and shear loads in uncracked normal-weight or uncracked lightweight concrete having a specified compressive strength,  $f'_c$ , of 2,500 psi to 8,500 psi (17.2 MPa to 58.6 MPa).

The SRS+ Carbon Steel Wedge Anchor  $3/8$ -inch-diameter (9.5 mm),  $1/2$ -inch-diameter (12.7 mm) and  $5/8$ -inch-diameter (15.9 mm) anchors must be designed according to ACI 318 Chapter 17 and Sections 4.1 and 4.2 of this report for single anchor applications or in group anchorages, as applicable.

The MKT SRS Stainless Steel Wedge Anchor  $1/4$ -inch-diameter (6.4 mm) may only be used for redundant applications, where multiple anchors support linear elements (e.g., ductwork), if designed according to Section 4.3 of this report. In redundant applications, the anchors can be used in cracked and uncracked normal-weight and lightweight concrete having a specified compressive strength,  $f'_c$ , of 2,500 psi to 8,500 psi (17.2 MPa to 58.6 MPa).

The MKT SRS+ / SRS anchors comply with anchors installed in hardened concrete as described in Section 1901.3 of the 2024 IBC, or are an alternative to cast-in-place anchors described in Section 1901.3 of the 2024. The anchors may also be used where an engineered design is submitted in accordance with Section R301.1.3 of the IRC.

### 3.0 DESCRIPTION

#### 3.1 MKT SRS+ and SRS:

SRS+ and SRS anchors are torque-controlled, mechanical expansion anchors consisting of a stud anchor body, expansion clip, nut, and washer. The anchors are available in diameters of  $\frac{1}{4}$ -inch,  $\frac{3}{8}$ -inch,  $\frac{1}{2}$ -inch and  $\frac{5}{8}$ -inch (6.4 mm, 9.5 mm, 12.7 mm and 15.9 mm) and are illustrated in [Figure 1](#) of this report.

MKT SRS  $\frac{1}{4}$ -inch diameter anchors: The stud, expansion clip, conical bolt, washer and nut are fabricated from stainless steel.

MKT SRS+  $\frac{3}{8}$ -inch,  $\frac{1}{2}$ -inch and  $\frac{5}{8}$ -inch diameter anchors: The stud is manufactured from carbon steel and has a minimum 5  $\mu\text{m}$  (0.0002 inch) zinc plating. The expansion clip is fabricated from stainless steel. The carbon steel hex nuts comply with ASTM A563, Grade A. The washers comply with ANSI/ASME B18.22.1.

The stud anchor body has a tapered mandrel formed on the installed end of the anchor, and a threaded section at the opposite end. The taper of the mandrel increases in diameter toward the installed end of the anchor. The two-segment expansion clip wraps around the tapered mandrel. Before installation, this expansion clip is free to rotate about the mandrel. The anchor is installed in a predrilled hole with a hammer. When the anchor is set using an applied torque to the hex nut, the mandrel is drawn into the expansion clip, which engages the wall of the drilled hole and transfers the load to the base material. Pertinent dimensions are as set forth in [Table 1](#) and [Table 6](#).

#### 3.2 Concrete:

Normal-weight and lightweight concrete must comply with Sections 1903 and 1905 of the IBC.

### 4.0 DESIGN AND INSTALLATION

#### 4.1 Strength Design (Structural):

**4.1.1 General:** Design Strength of anchors complying with the complying with 2024 IBC, as well as Section R301.1.3 of the 2024 IRC must be determined in accordance with ACI 318-19 Chapter 17 and this report.

Design parameters are based on the 2024 IBC (ACI 318-19), unless noted otherwise in Sections 4.1.1 through 4.1.11 of this report. The strength design of anchors must comply with ACI 318-19 Section 17.5.1.2. Strength reduction factors  $\phi$  as given in ACI 318-19 Section 17.5.3 must be used for load combinations calculated in accordance with Section 1605.1 of the 2024 IBC or Section 5.3 of ACI 318-19. An example calculation in accordance with the 2024 IBC is provided in [Figure 4](#). The value of  $f'_c$  used in calculations must be limited to a maximum of 8,000 psi (55.2 MPa) in accordance with ACI 318-19 Section 17.3.1.

**4.1.2 Requirements for Static Steel Strength in Tension,  $N_{sa}$ :** The nominal steel strength of a single anchor in tension,  $N_{sa}$ , in accordance with ACI 318-19 Section 17.6.1, are described in [Table 3](#) of this report. Strength reduction factors,  $\phi_{sa}$ , corresponding to ductile steel elements as described in [Table 3](#) of this report are appropriate.

**4.1.3 Requirements for Static Concrete Breakout Strength in Tension,  $N_{cb}$  or  $N_{cbg}$ :** The nominal concrete breakout strengths of a single anchor or a group of anchors in tension,  $N_{cb}$  and  $N_{cbg}$ , respectively, must be calculated in accordance with ACI 318-19 Section 17.6.2, with modifications as described in this section. The basic concrete breakout strength in tension,  $N_b$ , must be calculated in accordance with ACI 318-19 Section 17.6.2.2 using the values of  $h_{ef}$  and  $k_{uncr}$  as given in [Table 3](#) in lieu of  $h_{ef}$  and  $k_c$ , respectively, using a  $\psi_{CN} = 1.0$ .

**4.1.4 Requirements for Static Pullout Strength in Tension,  $N_{pn}$ :** The nominal pullout strength of a single anchor in tension in accordance with ACI 318-19 Sections 17.6.3.1 and 17.6.3.2.1,  $N_{p,uncr}$ , where applicable, is given in [Table 3](#). The nominal pullout strength in tension may be adjusted by calculations according to Eq-1:

$$N_{pn,f'_c} = N_{pn,uncr} \left( \frac{f'_c}{2,500} \right)^{0.5} \quad (\text{lb, psi}) \quad (\text{Eq-1})$$

$$N_{pn,f'_c} = N_{pn,uncr} \left( \frac{f'_c}{17.2} \right)^{0.5} \quad (\text{N, MPa})$$

where  $f'_c$  is the specified concrete compressive strength.

Where values for  $N_{p,uncr}$  are not provided in [Table 3](#) of this report, the pullout strength in tension does not need to be considered.

**4.1.5 Requirements for Static Steel Strength in Shear,  $V_{sa}$ :** The nominal static steel strength in shear,  $V_{sa}$ , of a single anchor is given in [Table 4](#) of this report and must be used in lieu of the values derived by calculation from ACI 318-19 Eq. 17.7.1.2b. Strength reduction factors,  $\Phi_{sa}$ , corresponding to ductile steel elements as described in [Table 4](#) are appropriate.

**4.1.6 Requirements for Static Concrete Breakout Strength in Shear,  $V_{cb}$  or  $V_{cbg}$ :** The nominal concrete breakout strengths of a single anchor or a group of anchors in shear,  $V_{cb}$  or  $V_{cbg}$ , respectively, must be calculated in accordance with ACI 318-19 Section 17.7.2, with modifications as described in this section. The basic concrete breakout strength in shear,  $V_b$ , must be calculated in accordance with ACI 318-19 Section 17.7.2.2.1 using the values of  $l_e$  and  $d_a$  described in [Table 4](#) of this report. The value of  $l_e$  used in ACI 318-19 Eq. 17.7.2.2.1a must be taken as no greater than the lesser of  $h_{ef}$  or  $8d_a$ .

**4.1.7 Requirements for Static Concrete Pryout Strength in Shear,  $V_{cp}$  or  $V_{cpG}$ :** Static nominal concrete pryout strength of a single anchor or a group of anchors,  $V_{cp}$  or  $V_{cpG}$ , respectively, must be calculated in accordance with ACI 318-19 Section 17.7.3, modified by using the value of  $k_{cp}$  provided in [Table 4](#) of this report and the value of  $N_{cb}$  or  $N_{cbG}$  as calculated in accordance with Section 4.1.3 of this report.

**4.1.8 Requirements for Interaction of Tensile and Shear forces:** Anchors or groups of anchors that are subject to the effects of combined tensile and shear forces must be designed in accordance with ACI 318-19 Section 17.8.

**4.1.9 Requirements for Critical Edge Distance,  $c_{ac}$ :** In applications where  $c < c_{ac}$  and supplemental reinforcement to control splitting of the concrete is not present, the concrete breakout strength in tension for uncracked concrete, calculated according to ACI 318-19 Section 17.6.2, must be further multiplied by the factor  $\Psi_{cp,N}$  given by the following equation:

$$\Psi_{cp,N} = \frac{c}{c_{ac}} \quad (\text{Eq-2})$$

where the factor  $\Psi_{cp,N}$  need not be taken as less than  $1.5h_{ef}/c_{ac}$ .

For all other cases,  $\Psi_{cp,N}=1.0$ . In lieu of ACI 318-19 Section 17.9.5, values of  $c_{ac}$  provided in [Table 3](#) of this report must be used.

**4.1.10 Requirements for Minimum Member Thickness, Minimum Anchor Spacing, and Minimum Edge Distance:** In lieu of ACI 318-19 Section 17.9.2, values of  $s_{min}$  and  $c_{min}$  as given in [Table 1](#) of this report must be used. In lieu of ACI 318-19 Section 17.9.4, minimum member thicknesses,  $h_{min}$ , as given in [Table 1](#) of this report must be used.

**4.1.11 Lightweight Concrete:** For the use of anchors in lightweight concrete, the modification factor  $\lambda_a$  equal to  $0.8\lambda$  is applied to all values of  $\sqrt{f'_c}$  affecting  $N_n$  and  $V_n$ .

The value of  $\lambda$  shall be determined in accordance with ACI 318-19.

## 4.2 Allowable Stress Design (ASD, Structural):

**4.2.1 General:** Design resistances for use with allowable stress design load combinations calculated in accordance with Section 1605.1 of the 2024 IBC must be established using the following relationships:

$$T_{allowable, ASD} = \Phi N_n / \alpha \quad (\text{Eq-3})$$

and

$$V_{allowable, ASD} = \Phi V_n / \alpha \quad (\text{Eq-4})$$

where:

$T_{allowable, ASD}$  = Allowable tension load (lbf or N).

$V_{allowable, ASD}$  = Allowable shear load (lbf or N).

$\Phi N_n$  = Lowest design strength of an anchor or anchor group in tension as determined in accordance with ACI 318-19 Section 17.5.1.2, 2024 IBC Section 1905.7, and Section 4.1 of this report, as applicable (lbf or kN).

$\Phi V_n$  = Lowest design strength of an anchor or anchor group in shear as determined in accordance with ACI 318-19 Section 17.5.1.2, 2024 IBC Section 1905.7, and Section 4.1 of this report, as applicable (lbf or kN).

$\alpha$  = Conversion factor calculated as a weighted average of the load factors for the controlling load combination. In addition,  $\alpha$  must include all applicable factors to account for nonductile failure modes and required overstrength.

The requirements for member thickness, edge distance and spacing, described in this report, must apply.

[Table 5](#) illustrates calculated example ASD values for each anchor diameter and embedment.

**4.2.2 Interaction of Tensile and Shear Forces:** Interaction of tensile and shear loads must be calculated in accordance and consistent with ACI 318-19 Section 17.8 as follows:

If  $T_{applied} \leq 0.2T_{allowable,ASD}$ , then the full allowable strength in shear,  $V_{allowable,ASD}$ , must be permitted.

If  $V_{applied} \leq 0.2V_{allowable,ASD}$ , then the full allowable strength in tension,  $T_{allowable,ASD}$ , must be permitted.

For all other cases:

$$\frac{T_{applied}}{T_{allowable,ASD}} + \frac{V_{applied}}{V_{allowable,ASD}} \leq 1.2 \quad (\text{Eq-5})$$

### 4.3 Redundant fastening Design (Nonstructural)

**4.3.1 General:** For an anchoring system designed with redundancy, the load maintained by an anchor that experiences failure or excessive deflection must be transmitted to neighboring anchors without significant consequences to the item being attached or remaining resistance of the anchoring system. In addition to the requirements for anchors, the item being attached must be able to resist the forces acting on it assuming one of the fixing points is not carrying load. It is assumed that by adhering to and specifying the limits shown for n1, n2 and n3 illustrated in [Figures 5](#) and [6](#) of this report, redundancy is satisfied, where n1 is the total number of anchorage points supporting the linear element, n2 is the number of anchors per anchorage point and n3 is the factored design load,  $N_{ua}$  or  $V_{ua}$ , or a combination of both on an anchorage point based on the critical load combination from 2024 IBC Section 1605.1 or ACI 318-19 Section 5.3.

For redundant fastening, the MKT SRS  $1/4$  inch is used to resist tension and shear loads, or any combination thereof, in accordance with Section 2.0 of this report and with the following limitations:

- Applications must be limited to the support of nonstructural elements.
- Single anchor point applications are prohibited.
- Anchor design must be limited to structures assigned to IBC Seismic Design category A or B only.
- The specified concrete compressive strength  $f'_c$  used for calculation purpose must be equal 2,500 psi (17.2 MPa).

**4.3.2 Strength Design:** For redundant applications of anchors in concrete loaded in tension and shear, the following equations must be satisfied:

$$\phi_{ra}F_{ra} \geq N_{ua} \quad (\text{Eq-6})$$

$$\phi_{ra}F_{ra} \geq V_{ua} \quad (\text{Eq-7})$$

where:

$F_{ra}$  = the characteristic strength (resistance) for the anchors in [Table 6](#) of this report (lb or kN)

$N_{ua}$  = factored tensile force applied at each anchorage point (lb or kN)

$V_{ua}$  = factored shear force applied at each anchorage point (lbf or kN)

Corresponding strength reduction factors for redundant applications,  $\phi_{ra}$ , are given in [Table 6](#).  $F_{ra}$  is independent of load direction and applicable for cracked and uncracked concrete. For combined tension and shear loading of redundant applications, the following equation must be satisfied:

$$\phi_{ra}F_{ra} \geq \sqrt{(N_{ua})^2 + (V_{ua})^2} \quad (\text{Eq-8})$$

For redundant applications of anchors installed in lightweight concrete, the design strength  $\phi_{ra}F_{ra}$  in Eq-6, Eq-7 and Eq-8 must be further multiplied by the modification factor,  $\lambda_a$ , as applicable. See Section 4.1.11 of this report.

**4.3.3 Allowable Stress Design (ASD):** Design values for redundant applications of anchors for use with Allowable Stress Design must be calculated in accordance with Section 4.3.2 of this report and Eq-9:

$$R_{allowable,ASD} = \frac{\phi_{ra} F_{ra}}{\alpha} \quad (\text{Eq-9})$$

where  $R_{allowable,ASD}$  is the allowable load (lbf or kN) for redundant applications and where  $\alpha$  is the conversion factor calculated as a weighted average of the load factors for the controlling load combination. The conversion factor,  $\alpha$ , is equal to 1.4 assuming dead load only.

**4.3.4 Requirements for Minimum Member Thickness, Critical Edge Distance, Minimum Anchor Spacing and Minimum Edge Distance:** The values of  $c_{min}$ ,  $c_{ac}$ ,  $s_{min}$  and  $h_{min}$  must comply with [Table 6](#) of this report.

#### 4.4 Installation:

Installation parameters are provided in [Table 1](#), [Table 6](#) and in [Figure 2](#). The manufacturer's printed installation instructions (MPII) are reproduced in [Figure 3](#). Anchor locations must comply with this report and the plans and specifications approved by the code official. MKT SRS+ / SRS anchors must be installed in accordance with the manufacturer's published installation instructions. Holes must be predrilled in concrete with a compressive strength from 2,500 to 8,500 psi (17.2 to 58.6 MPa), using carbide-tipped masonry drill bits manufactured within the range of the maximum and minimum drill tip dimensions of ANSI B212.15-1994. The nominal diameter of the carbide-tipped drill bit must equal the anchor diameter. Holes must be created by drilling to the required minimum hole depth,  $h_{hole}$ , as described in [Table 1](#) and [Table 6](#) of this report. Prior to installation, dust and debris must be removed from the drilled hole to enable installation to the required embedment depth. The nut and washer must be assembled on the end of the anchor, leaving the nut slightly below the end of the anchor. The anchors are then driven through the fixture to the required embedment depth in concrete. The nut and washer must be tightened against the base material or item to be fastened until the appropriate installation torque value,  $T_{inst}$ , as specified in [Table 1](#) and [Table 6](#) of this report is achieved.

#### 4.5 Special Inspection:

Periodic special inspection is required in accordance with Section 1705.1.1 and Table 1705.3 of the 2024 IBC. The special inspector must make periodic inspections during anchor installation to verify anchor type, anchor dimensions, concrete type, concrete compressive strength, hole dimensions, drill bit size, hole cleanliness, edge distance, anchor spacing, concrete thickness, embedment depth, tightening torque, and adherence to the MPII.

The special inspector must be present as often as required in accordance with the "statement of special inspection".

## 5.0 CONDITIONS OF USE:

The MKT SRS+ / SRS Wedge Anchors described in this report comply with, or are suitable alternatives to what is specified in, those codes listed in Section 1.0 of this report, subject to the following conditions:

- 5.1 Anchor sizes, dimensions, and other installation parameters are as set forth in this report.
- 5.2 The anchors must be installed in accordance with [Figure 3](#) and this report. In case of conflicts, this report governs.
- 5.3 The MKT SRS  $1/4$ -inch diameter (6.4 mm) anchors may be installed in cracked or uncracked, normal-weight or lightweight concrete having a specified compressive strength,  $f'_c$ , of 2,500 psi to 8,500 psi (17.2 MPa to 58.6 MPa). The MKT SRS+  $3/8$ -inch-diameter (9.5 mm),  $1/2$ -inch-diameter (12.7 mm) and  $5/8$ -inch-diameter (15.9 mm) anchors may be installed in uncracked, normal-weight or lightweight concrete having a specified compressive strength,  $f'_c$ , of 2,500 psi to 8,500 psi (17.2 MPa to 58.6 MPa).
- 5.4 The values of  $f'_c$  used for calculation purposes must not exceed 8,000 psi (55.2 MPa); for redundant fastenings (nonstructural) the values of  $f'_c$  used for calculation purpose must equal 2,500 psi (17.2 MPa).
- 5.5 Strength design values must be established in accordance with Section 4.1 of this report.
- 5.6 Allowable stress design values must be established in accordance with Section 4.2 of this report.
- 5.7 Redundant fastening design values must be established in accordance with Section 4.3 of this report.
- 5.8 Anchor spacing, edge distance, and minimum member thickness must comply with [Table 1](#) of this report.
- 5.9 Prior to installation, calculations and details justifying that the applied loads demonstrate compliance with this report must be submitted to the code official for approval. The calculations and details must be prepared

by a registered design professional where required by the statutes of the jurisdiction in which the project is to be constructed.

- 5.10** Since ICC-ES acceptance criteria for evaluating data to determine the performance of expansion anchors subjected to fatigue or shock loading is unavailable at this time, the use of these anchors under such conditions is beyond the scope of this report.
- 5.11** The MKT SRS  $\frac{1}{4}$ -inch-diameter anchors may be installed in regions of concrete where cracking has occurred or where analysis indicates cracking may occur ( $f_t > f_r$ ), subject to the conditions of this report.
- 5.12** Use of SRS+ anchors in structures assigned to Seismic Design Category C, D, E or F is beyond the scope of this report. Anchors may be used to resist short-term loading due to wind or seismic forces (Seismic Design Category A and B), subject to the conditions of this report.
- 5.13** Where not otherwise prohibited in the code, SRS+ anchors are permitted for use with fire-resistance-rated construction provided that at least one of the following conditions is fulfilled:
- Anchors are used to resist wind or seismic forces only.
  - Anchors that support a fire-resistance-rated envelope or a fire-resistance-rated membrane are protected by approved fire-resistance-rated materials, or have been evaluated for resistance to fire exposure in accordance with recognized standards.
  - Anchors are used to support nonstructural elements.
- 5.14** For redundant applications, the ability of the fixed element to transfer loads to adjacent anchors must be justified to the satisfaction of the code official by the design professional.
- 5.15** Use of the zinc-coated carbon steel anchor (MKT SRS+) is limited to dry, interior locations. Use of the stainless steel anchor (MKT SRS) is permitted for exterior exposure or damp environments.
- 5.16** Special inspections are provided in accordance with Section 4.5 of this report.
- 5.17** Anchors are manufactured in Lonoke, Arkansas, under an approved quality-control program with inspections by ICC-ES.

## 6.0 EVIDENCE SUBMITTED

Data in accordance with the [ICC-ES Acceptance Criteria for Mechanical Anchors in Concrete Elements AC193 \(24\)](#), dated April 2025, which incorporates requirements in ACI 355.2; and quality-control documentation.

## 7.0 IDENTIFICATION

- 7.1** The ICC-ES mark of conformity, electronic labeling, or the evaluation report number (ICC-ES ESR-3782) along with the name, registered trademark, or registered logo of the report holder must be included in the product label.
- 7.2** In addition, the anchors are identified by packaging labeled with the anchor name and size, the manufacturer's name (MKT) and contact information. A length identification code is stamped on the threaded end of the anchor as indicated in [Table 2](#) and the identifying mark of the manufacturing plant ( $\diamond$ ) is stamped on the expansion sleeve.
- 7.3** The following report holder's contact information is the following:

**MKT FASTENING, LLC**  
**1 GUNNEBO DRIVE**  
**LONOKE, ARKANSAS 72086**  
**(501) 676-2222**  
[www.mktfasteningusa.com](http://www.mktfasteningusa.com)  
[Louis.Peyron@mktfasteningusa.com](mailto:Louis.Peyron@mktfasteningusa.com)

TABLE 1—MKT SRS+ INSTALLATION INFORMATION<sup>1</sup>

SETTING INFORMATION	SYMBOL	UNITS	NOMINAL ANCHOR DIAMETER		
			<sup>3</sup> / <sub>8</sub> inch	<sup>1</sup> / <sub>2</sub> inch	<sup>5</sup> / <sub>8</sub> inch
Nominal Diameter	$d_a$	in. (mm)	<sup>3</sup> / <sub>8</sub> (9.5)	<sup>1</sup> / <sub>2</sub> (12.7)	<sup>5</sup> / <sub>8</sub> (15.9)
Drill Bit Diameter	$d_{bit}$	in. (mm)	<sup>3</sup> / <sub>8</sub>	<sup>1</sup> / <sub>2</sub>	<sup>5</sup> / <sub>8</sub>
Minimum Hole Depth	$h_{hole}$	in. (mm)	2 <sup>7</sup> / <sub>8</sub> (73)	2 <sup>7</sup> / <sub>8</sub> (73)	3 <sup>3</sup> / <sub>4</sub> (95)
Minimum Base Plate Clearance Hole Diameter <sup>2</sup>	$d_c$	in. (mm)	7 <sup>7</sup> / <sub>16</sub> (11.1)	9 <sup>9</sup> / <sub>16</sub> (14.3)	11 <sup>11</sup> / <sub>16</sub> (17.5)
Installation Torque	$T_{inst}$	ft-lbf (N-m)	20 (27)	40 (54)	60 (81)
Embedment Depth	$h_{nom}$	in. (mm)	2 <sup>7</sup> / <sub>16</sub> (62)	2 <sup>9</sup> / <sub>16</sub> (65)	3 <sup>3</sup> / <sub>8</sub> (86)
Effective Embedment Depth	$h_{ef}$	in. (mm)	2 (51)	2 (51)	2 <sup>3</sup> / <sub>4</sub> (70)
Minimum Edge Distance	$c_{min}$	in. (mm)	2 (51)	2 <sup>1</sup> / <sub>2</sub> (64)	2 <sup>1</sup> / <sub>4</sub> (57)
Minimum Anchor Spacing	$s_{min}$	in. (mm)	2 <sup>7</sup> / <sub>8</sub> (73)	3 (76)	5 <sup>1</sup> / <sub>4</sub> (133)
Minimum Concrete Thickness	$h_{min}$	in. (mm)	4 (102)	5 (127)	5 (127)

For SI: 1 inch = 25.4 mm, 1 ft-lbf = 1.356 N-m.

<sup>1</sup> The information presented in this table must be used in conjunction with the design requirements of ACI 318-19 Chapter 17.

<sup>2</sup> The clearance must comply with applicable code requirements for the connected element.

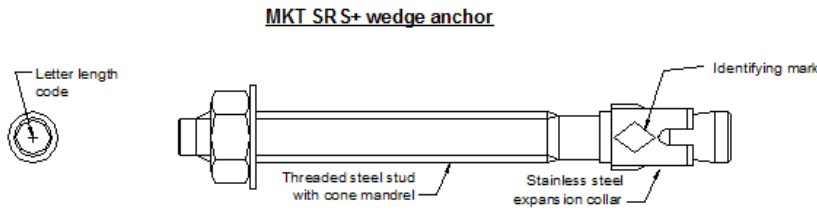

FIGURE 1—MKT SRS+ ANCHOR

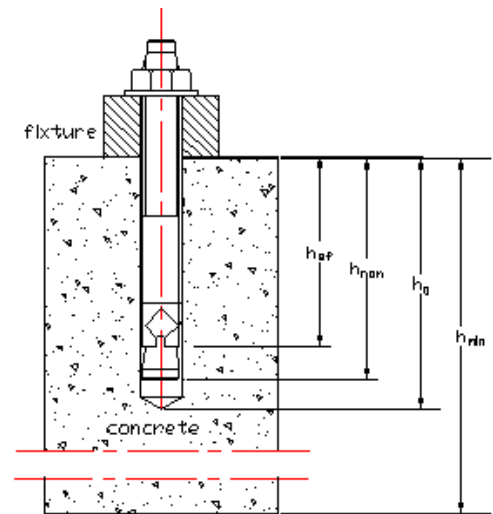
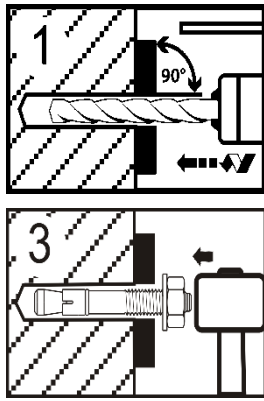

FIGURE 2—MKT SRS+ ANCHOR (INSTALLED)

TABLE 2—LENGTH IDENTIFICATION SYSTEM

Length ID marking on stud	A	B	C	D	E	F	G	H	I	J	K	L	M	N	O	P	Q	R	S	T	U	V	W
Length of anchor min ≥ (in.)	1 <sup>1</sup> / <sub>2</sub>	2	2 <sup>1</sup> / <sub>2</sub>	3	3 <sup>1</sup> / <sub>2</sub>	4	4 <sup>1</sup> / <sub>2</sub>	5	5 <sup>1</sup> / <sub>2</sub>	6	6 <sup>1</sup> / <sub>2</sub>	7	7 <sup>1</sup> / <sub>2</sub>	8	8 <sup>1</sup> / <sub>2</sub>	9	9 <sup>1</sup> / <sub>2</sub>	10	11	12	13	14	15
Length of anchor max < (in.)	2	2 <sup>1</sup> / <sub>2</sub>	3	3 <sup>1</sup> / <sub>2</sub>	4	4 <sup>1</sup> / <sub>2</sub>	5	5 <sup>1</sup> / <sub>2</sub>	6	6 <sup>1</sup> / <sub>2</sub>	7	7 <sup>1</sup> / <sub>2</sub>	8	8 <sup>1</sup> / <sub>2</sub>	9	9 <sup>1</sup> / <sub>2</sub>	10	11	12	13	14	15	16



Step 1:  
Select the correct diameter drill bit, drill a hole to required hole depth.

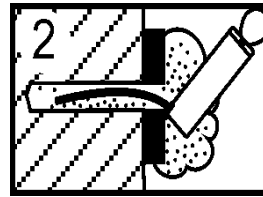

Step 2:  
Remove drilling debris from the bottom of the drill hole using a blowout bulb, or compressed air or vacuum.

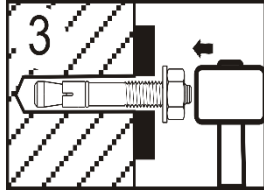

Step 3:  
Assemble the nut & washer past the impact end of the SRS+. Use a hammer to tap the anchor through the part being fastened into the drilled hole to the required minimum embedment,  $h_{nom}$ , until the washer is in contact with the part.

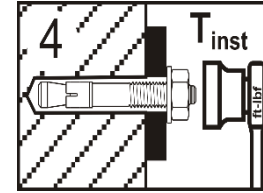

Step 4:  
Using a torque wrench, apply the specified installation torque to the anchor.

FIGURE 3—MANUFACTURER’S PUBLISHED INSTALLATION INSTRUCTIONS (MPII)

TABLE 3—MKT SRS+ CHARACTERISTIC TENSION STRENGTH DESIGN INFORMATION<sup>1</sup>

CHARACTERISTIC	SYMBOL	UNITS	NOMINAL ANCHOR DIAMETER		
			<sup>3</sup> / <sub>8</sub> inch	<sup>1</sup> / <sub>2</sub> inch	<sup>5</sup> / <sub>8</sub> inch
Anchor Category	1, 2 or 3	-	1	1	1
Nominal Embedment Depth	$h_{nom}$	in. (mm)	2 <sup>7</sup> / <sub>16</sub> (62)	2 <sup>9</sup> / <sub>16</sub> (65)	3 <sup>3</sup> / <sub>8</sub> (86)
<b>Steel Strength in Tension (ACI 318-19 Section 17.6.1.2)</b>					
Specified Yield Strength	$f_{ya}$	psi (N/mm <sup>2</sup> )	84,000 (579)	84,000(579)	84,000 (579)
Specified Tensile Strength	$f_{uta}$	psi (N/mm <sup>2</sup> )	90,000 (620)	88,000 (606)	90,000 (620)
Effective Tensile Stress Area	$A_{se,N}$	in <sup>2</sup> (mm <sup>2</sup> )	0.056 (36)	0.109 (70)	0.173 (112)
Tension Resistance of Steel	$N_{sa}$	lbf (kN)	5,040 (22.3)	9,592 (42.4)	15,570 (69.2)
Strength Reduction Factor-Steel Failure <sup>2</sup>	$\Phi_{sa}$	-	0.75	0.75	0.75
<b>Concrete Breakout Strength in Tension (ACI 318-19 Section 17.6.2)</b>					
Effective Embedment Depth	$h_{ef}$	in. (mm)	2 (51)	2 (51)	2 <sup>3</sup> / <sub>4</sub> (70)
Critical Edge Distance	$c_{ac}$	in. (mm)	4 <sup>1</sup> / <sub>2</sub> (114)	4 <sup>7</sup> / <sub>8</sub> (124)	7 <sup>1</sup> / <sub>2</sub> (191)
Effectiveness Factor-Uncracked Concrete	$k_{unscr}$	-	24 (10)	30 (12.5)	30 (12.5)
Strength Reduction Factor-Concrete Breakout Failure <sup>3</sup>	$\Phi_{cb}$	-	0.65	0.65	0.65
<b>Pull-Out Strength in Tension (ACI 318-19 Section 17.6.3)</b>					
Pull-Out Resistance Uncracked Concrete ( $f'_c = 2,500$ psi) <sup>5</sup>	$N_{pn,unscr}$	lbf (kN)	3,027 (13.5)	N/A <sup>4</sup>	N/A <sup>4</sup>
Strength Reduction Factor-Pullout Failure <sup>6</sup>	$\Phi_p$	-	0.65	0.65	0.65
<b>Axial stiffness</b>					
Axial stiffness	$\beta$	lb/in (N/mm)	24,888 (4,335)	102,421 (17,924)	49,341 (8,635)

For SI: 1 inch = 25.4mm, 1lbf = 4.45N, 1 lb/in = 0.175 N/mm, 1 psi = 0.00689 MPa = 0.00689 N/mm<sup>2</sup>, 1 in<sup>2</sup> = 645 mm<sup>2</sup>, 1 lb/in = 0.175 N/mm.

<sup>1</sup> The information presented in this table must be used in conjunction with the design requirements of ACI 318 Chapter 17.  
<sup>2</sup> The tabulated value of  $\Phi_{sa}$  applies when the load combinations of Section 1605.1 of the 2024 IBC or ACI 318-19 Section 5.3 are used. The anchors are ductile steel elements as defined in ACI 318-19 Section 2.3.  
<sup>3</sup> The tabulated value of  $\Phi_{cb}$  applies when both the load combinations of Section 1605.1 of the 2024 IBC or ACI 318-19 Section 5.3 are used and the requirements of ACI 318-19 Section 17.5.3 for supplementary reinforcement not present (Condition B) are satisfied.  
<sup>4</sup> As described in Section 4.1.4 of this report, N/A (Not Applicable) denotes that pullout resistance is not critical and does not need to be considered.  
<sup>5</sup> The characteristic pull-out resistance for greater than 2,500 psi concrete compressive strengths may be increased by multiplying the tabular value by  $(f'_c / 2,500)^{0.5}$ .  
<sup>6</sup> The tabulated value of  $\Phi_p$  applies if the load combinations of Section 1605.1 of the 2024 IBC or ACI 318-19 Section 5.3 are used.

TABLE 4—MKT SRS+ CHARACTERISTIC SHEAR STRENGTH DESIGN INFORMATION<sup>1</sup>

CHARACTERISTIC	SYMBOL	UNITS	NOMINAL ANCHOR DIAMETER		
			<sup>3</sup> / <sub>8</sub> inch	<sup>1</sup> / <sub>2</sub> inch	<sup>5</sup> / <sub>8</sub> inch
Anchor Category	1, 2 or 3	-	1	1	1
Nominal Embedment Depth	$h_{nom}$	in.	2 <sup>7</sup> / <sub>16</sub> (62)	2 <sup>9</sup> / <sub>16</sub> (65)	3 <sup>3</sup> / <sub>8</sub> (86)
<b>Steel Strength in Shear (ACI 318-19 Section 17.7.1)</b>					
Specified Yield Strength for Shear	$f_{ya}$	psi (N/mm <sup>2</sup> )	84,000 (579)	84,000 (579)	84,000 (579)
Specified Tensile Strength for Shear	$f_{uta}$	psi (N/mm <sup>2</sup> )	90,000 (620)	88,000 (606)	90,000 (606)
Effective Shear Stress Area	$A_{se,V}$	in <sup>2</sup> (mm <sup>2</sup> )	0.0775 (50)	0.142 (92)	0.226 (146)
Shear Resistance of Steel	$V_{sa}$	lbf (kN)	3,244 (14.4)	5,453 (24.2)	10,188 (45.3)
Strength Reduction Factor-Steel Failure <sup>2</sup>	$\Phi_{sa}$	-	0.65	0.65	0.65
<b>Concrete Breakout Strength in Shear (ACI 318-19 Section 17.7.2)</b>					
Nominal Diameter	$d_o$	in.	<sup>3</sup> / <sub>8</sub> (9.5)	<sup>1</sup> / <sub>2</sub> (12.7)	<sup>5</sup> / <sub>8</sub> (15.9)
Load Bearing Length of Anchor in Shear	$l_e$	in.	2 (51)	2 (51)	2 <sup>3</sup> / <sub>4</sub> (70)
Strength Reduction Factor-Concrete Breakout Failure <sup>3</sup>	$\Phi_{cb}$	-	0.70	0.70	0.70
<b>Concrete Pryout Strength in Shear (ACI 318 Section 17.7.3)</b>					
Coefficient for Pryout Strength	$k_{cp}$	-	1	1	2
Strength Reduction Factor-Concrete Pryout Failure <sup>4</sup>	$\Phi_{cp}$	-	0.7	0.7	0.7

For SI: 1 inch = 25.4mm, 1 lbf = 4.45 N, 1 psi = 0.00689 MPa = 0.00689 N/mm<sup>2</sup>, 1 in<sup>2</sup> = 645 mm<sup>2</sup>.

<sup>1</sup> The information presented in this table must be used in conjunction with the design criteria of ACI 318-19 Chapter 17.

<sup>2</sup> The tabulated value of  $\Phi_{sa}$  applies when the load combinations of Section 1605.1 of the 2024 IBC or ACI 318-19 Section 5.3 are used. The anchors are ductile steel elements as defined in ACI 318-19 Section 2.3.

<sup>3</sup> The tabulated value of  $\Phi_{cb}$  applies when both the load combinations of Section 1605.1 of the 2024 IBC or ACI 318-19 Section 5.3 are used and the requirements of ACI 318-19 Section 17.5.3 for supplementary reinforcement not present (Condition B) are satisfied.

<sup>4</sup> The tabulated value of  $\Phi_{cp}$  applies if the load combinations of Section 1605.1 of the 2024 IBC or ACI 318-19 Section 5.3 are used.

TABLE 5—EXAMPLE ALLOWABLE STRESS DESIGN VALUES FOR ILLUSTRATIVE PURPOSES<sup>1,2,3,4,5,6,7,8,9</sup>

Nominal Anchor Diameter, $d_o$ (in.)	Embedment Depth, $h_{nom}$ (in.)	Effective Embedment Depth, $h_{ef}$ (in.)	Allowable Tension Load, $\Phi N_n / \alpha$ (lbf)
<sup>3</sup> / <sub>8</sub>	2 <sup>7</sup> / <sub>16</sub>	2	1,330
<sup>1</sup> / <sub>2</sub>	2 <sup>9</sup> / <sub>16</sub>	2	1,860
<sup>5</sup> / <sub>8</sub>	3 <sup>3</sup> / <sub>8</sub>	2 <sup>3</sup> / <sub>4</sub>	3,004

For SI: 1 inch = 25.4 mm, ft-lbf = 1.356 N-m, 1 lbf = 4.45 N.

<sup>1</sup> Single anchor with static tension load only

<sup>2</sup> Concrete determined to remain uncracked for the life of the anchorage

<sup>3</sup> Load combination from ACI 318-19 Section 5.3 (no seismic loading) with  $\Phi_{sa} = 0.75$ ,  $\Phi_{cb} = 0.65$ , and  $\Phi_p = 0.65$ .

<sup>4</sup> 30% dead load and 70% live load. Controlling load combination is 1.2D + 1.6L.

<sup>5</sup> Calculation of  $\alpha$  based on weighted average:  $\alpha = 0.3 \cdot 1.2 + 0.7 \cdot 1.6 = 1.48$

<sup>6</sup>  $f'_c = 2,500$  psi (normal weight concrete)

<sup>7</sup>  $C_{a1} = C_{a2} \geq C_{ac}$

<sup>8</sup>  $h \geq h_{min}$

<sup>9</sup> Values are for Condition B, supplementary reinforcement not present in accordance with ACI 318-19 Section 17.5.3.

Determine if two 1/2 inch diameter MKT SRS+ anchors with an effective embedment depth  $h_{ef} = 2$  inches installed 6 inches from center to center and 3 inches from the edge of a 6-inch deep slab is adequate for a service tension load of 2,000 lb. for wind and a reversible service shear load of 400 lb. for wind. The anchor group will be in the compression zone, away from other anchors in  $f'_c = 3,000$  psi normal – weight uncracked concrete

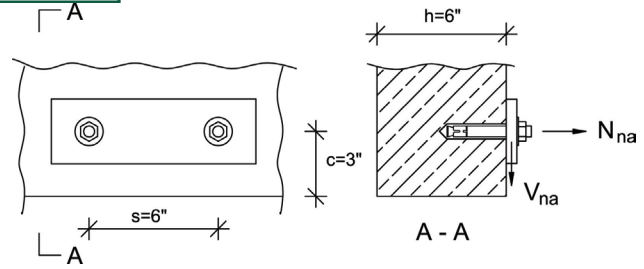

	ACI 318-19 Code Ref.	Report Ref.		ACI 318-19 Code Ref.	Report Ref.
1. <u>Verify minimum Member Thickness, Spacing and Edge Distance:</u>			calculating for $\frac{A_{Nc}}{A_{Nco}}$		
$h = 6 \text{ in.} \geq h_{min} = 5 \text{ in.}$ o.k.	17.9.4	<a href="#">Table 1</a>	$A_{Nco} = 9h_{ef}^2 = 9(2)^2 = 36 \text{ in.}^2$	Eq. (17.6.2.1.4)	
$s = 6 \text{ in.} \geq s_{min} = 3 \text{ in.}$ o.k.	17.9.2	<a href="#">Table 1</a>	$A_{Nc} = (ca + 1.5 h_{ef})(2 \times 1.5 h_{ef} + s)$	Fig. R17.6.2.1	
$c_{a,min} = 3 \text{ in.} \geq c_{min} = 2.5 \text{ in.}$ o.k.	17.9.2	<a href="#">Table 1</a>	$= (3 + 1.5 \times 2)(2 \times 1.5 \times 2 + 6)$		
			$= 72 \text{ in.}^2$		
2. <u>Determine the Factored Tension and Shear Design Loads:</u>			$\frac{A_{Nc}}{A_{Nco}} = \frac{72}{36} = 2.0$		
$N_{ua} = 1.6 W = 1.6 \times 2,000 = 3,200 \text{ lb.}$	5.3.1		Calculating for $N_b$ and $N_{cbg}$ :		
$V_{ua} = 1.6 W = 1.6 \times 400 = 640 \text{ lb.}$	5.3.5		$N_b = 30 \times 1.0 \times \sqrt{3,000} \times (2)^{1.5} = 4,648 \text{ lb.}$		
3. <u>Steel Capacity under Tension Loading:</u>	17.6.1.2		$N_{cbg} = 2.0 \times 1.0 \times 1.0 \times 1.0 \times 0.615 \times 4,648 = 5,717 \text{ lb.}$		
$N_{sa} = 9,592 \text{ lb.}$		<a href="#">Table 3</a>	$\Phi_{cb} = 0.65$ for Condition B (no supplementary reinforcement provided)	17.5.3	<a href="#">Table 3</a>
$\Phi = 0.75$	17.5.3	<a href="#">Table 3</a>	$\Phi_{cb} N_{cb} = 0.65 \times 5,717 = 3,716 \text{ lb.}$		
$n = 2$ (double anchor group)			5. <u>Pullout Capacity</u>	17.6.3	
Calculating for $\Phi N_{sa}$ :			$N_{pn,ucr}$ NA		<a href="#">Table 3</a>
$\Phi N_{sa} = 0.75 \times 2 \times 9,592 = 14,388 \text{ lb.}$			6. <u>Check all Failure Modes under Tension Loading:</u>	17.5.1	
4. <u>Concrete Breakout Capacity under Tension Loading</u>	17.6.2		Summary:		
$N_{cbg} = \frac{A_{Nc}}{A_{Nco}} \Psi_{ec,N} \Psi_{ed,N} \Psi_{c,N} \Psi_{cp,N} N_b$	Eq.(17.6.2.1b)		Steel Capacity =	14,388 lb	
where:			Concrete Breakout Capacity =	3,716 lb. ← Controls	
$N_b = k_c \lambda_a \sqrt{f'_c} h_{ef}^{1.5}$	Eq.(17.6.2.2.1)		Pullout Capacity =	NA	
with $k_c = k_{cr} = 30$		<a href="#">Table 3</a>	<b><math>\Phi N_n = 3,716 \text{ lb.}</math> as Concrete Breakout Capacity controls</b>		
$\lambda_a = 1.0$ for normal weight concrete	17.2.4		<b>&gt; <math>N_{ua} = 3,200 \text{ lb.}</math> - OK</b>		
$\Psi_{ec,N} = 1.0$ since eccentricity $e'_{N} = 0$	Eq.(17.6.2.3)		7. <u>Steel Capacity under Shear Loading:</u>	17.7.1	
$\Psi_{ed,N} = 1.0$ when $c_{a,min} \geq 1.5 h_{ef}$	Eq.(17.6.2.4)		Calculating for $\Phi V_{sa}$ :		
by observation $c_{a,min} = 3 \text{ in.} \geq 1.5 h_{ef} = 3 \text{ in.}$			$V_{sa} = 2 \times 5,453 = 11,128 \text{ lb.}$		<a href="#">Table 4</a>
$\Psi_{c,N} = 1.0$	Eq.(17.6.2.5)		$\Phi = 0.65$	17.5.3	<a href="#">Table 4</a>
$\Psi_{cp,N} = \frac{c_{a,min}}{c_{ac}} = \frac{3 \text{ in.}}{4^{7/8} \text{ in.}} = 0.615$	Eq.(17.6.2.6)		$\Phi V_{sa} = 0.65 \times 11,128 = 7,089 \text{ lb.}$		

FIGURE 4—SRS+ EXAMPLE CALCULATION

	ACI 318-19 Code Ref.	Report Ref.	ACI 318-19 Code Ref.	Report Ref.
8. <u>Concrete Breakout Capacity under Shear Loading:</u>	17.7.2		10. <u>Check all Failure Modes under Shear Loading:</u>	17.5.1
$V_{cbg} = \frac{A_{Vc}}{A_{Vc0}} \Psi_{ec,V} \Psi_{ed,V} \Psi_{c,V} V_b$		Eq. (17.7.2.1b)	Summary:	
where:			Steel Capacity = 7,089 lb.	
$V_b = 7 \left( \frac{l_e}{d_o} \right)^{0.2} \sqrt{d_o} \sqrt{f'_c} C_{a1}^{1.5}$		Eq. (17.7.2.2.1a)	Concrete Breakout Capacity = 3,042 lb. ← <b>Controls</b>	
$\Psi_{ec,V} = 1.0$ since eccentricity $e'_V = 0$		Eq. (17.7.2.3)	Pryout Capacity = 4,002 lb	
$\Psi_{ed,V} = 1.0$ since $C_{a2} > 1.5C_{a1}$		Eq. (17.7.2.4)		
$\Psi_{c,V} = 1.4$ for no cracking at service loads	17.7.2.5		<b><math>\Phi V_n = 3,042\text{lb.}</math> as Concrete Breakout Capacity controls <math>&gt; V_{ua} = 640\text{ lb.} - \text{OK}</math></b>	
calculating for $\frac{A_{Vc}}{A_{Vc0}}$			11. <u>Check Interaction of Tension and Shear Forces</u>	17.8
$h = 6 > 1.5 C_{a1} = 1.5 \times 3 = 4.5\text{ in.}$			If $0.2 \Phi V_n \geq V_{ua}$ then the full tension design strength is permitted.	17.8.2
$A_{Vc} = (2(1.5C_{a1}) + s_1) 1.5C_{a1}$		Fig. R17.7.2.1	By observation, this is not the case.	
$= (2 \times 1.5 \times 3 + 6) \times 1.5 \times 3$			If $0.2 \Phi N_n \geq N_{ua}$ then the full shear design strength is permitted.	17.8.2
$= 67.5\text{ in.}^2$			By observation, this is not the case.	
$A_{Vc0} = 4.5 (C_{a1})^2 = 4.5 \times 3^2 = 40.5\text{ in.}^2$		Eq. (17.7.2.1.3)	Therefore:	
$\frac{A_{Vc}}{A_{Vc0}} = \frac{67.5}{40.5} = 1.67$	17.7.2.1		$\frac{N_{ua}}{\Phi N_n} + \frac{V_{ua}}{\Phi V_n} \leq 1.2$	
calculating for $V_b$ and $\Phi V_{cbg}$			$\frac{3,200}{3,716} + \frac{640}{3,042} = 0.86 + 0.21 = 1.07 < 1.2 - \text{OK}$	
$d_a = 0.5\text{ in.}$		<a href="#">Table 4</a>	12. <u>Summary</u>	
$l_e = h_{ef} = 2\text{ in.}$	17.7.2.2.1		<b>Two 1/2 in. diameter SRS+ at 2 in. effective embedment depth are adequate to resist the applied service tension and shear loads of 2,000 lb. and 400 lb., respectively.</b>	
$C_{a1} = 3\text{ in.}$				
$\Phi_{cb} = 0.70$ for Condition B (no supplementary reinforcement provided)		<a href="#">Table 4</a>		
$V_b = 7 \times \left( \frac{2}{0.5} \right)^{0.2} \times \sqrt{0.5} \times \sqrt{3,000} \times (3)^{1.5} = 1,859\text{lb.}$				
$\Phi_{cb} V_{cbg} = 0.70 \times 1.67 \times 1.0 \times 1.0 \times 1.4 \times 1,859 = 3,042\text{lb.}$				
9. <u>Concrete Pryout Strength:</u>	17.7.3			
$V_{cpg} = k_{cp} N_{cbg}$		Eq. (17.7.3.1 b)		
where:				
$\Phi_{cp} = 0.70$		<a href="#">Table 4</a>		
$k_{cp} = 1.0$	17.7.3.1	<a href="#">Table 4</a>		
$V_{cpg} = k_{cp} N_{cbg} = 1.0 \times 5,717 = 5,717\text{ lb}$		Eq. (17.7.3.1b)		
$\Phi_{cp} V_{cpg} = 0.70 \times 5,717 = 4,002\text{ lb.}$				

FIGURE 4—SRS+ EXAMPLE CALCULATION (Continued)

A redundant system is achieved by specifying and limiting the following variables:

- $n_1$  = the total number of anchorage points supporting the linear element
- $n_2$  = the number of anchors per anchorage point
- $n_3$  = factored load at each anchorage point using the load combinations from IBC Section 1605.2 or ACI 318 Section 9.2

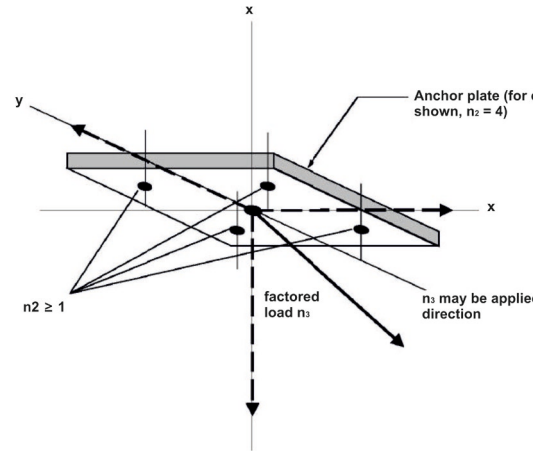
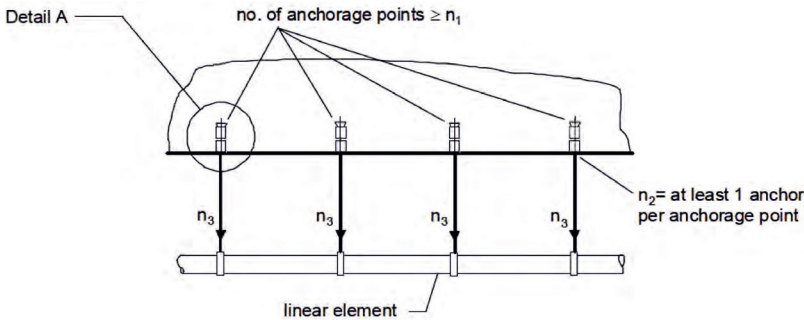

FIGURE 5—REDUNDANT FASTENING APPLICATION REQUIREMENTS FOR STRENGTH DESIGN OF TYPICAL FIXTURES

FIGURE 6—DETAIL A; ANCHORAGE POINT

TABLE 6—REDUNDANT FASTENING STRENGTH DESIGN INFORMATION FOR MKT SRS STAINLESS STEEL WEDGE ANCHORS <sup>1,2,5</sup>

ANCHOR PROPERTY / SETTING INFORMATION	SYMBOL	UNITS	NOMINAL ANCHOR SIZE	
			<sup>1</sup> / <sub>4</sub> inch	
Anchor category	1, 2 or 3	-	1	
Nominal anchor diameter	$d_a$ [ $d_o$ ]	in. (mm)	<sup>1</sup> / <sub>4</sub> (6.4)	
Nominal drill bit diameter	$d_{bit}$	in. (mm)	<sup>1</sup> / <sub>4</sub> (6.4)	
Installation Torque	$T_{inst}$	ft-lbf (N-m)	7.5 (10.2)	
Minimum nominal embedment depth	$h_{nom}$	in. (mm)	1.3 (33.2)	
Effective embedment depth	$h_{ef}$	in. (mm)	1 (25.4)	
Minimum member thickness	$h_{min}$	in. (mm)	3 (76)	
Minimum edge distance	$c_{min}=c_{ac}$	in. (mm)	4 (102)	
Minimum anchor spacing	$s_{min}$	in. (mm)	8 (203)	
Minimum hole depth	$h_{hole}$	in. (mm)	<sup>1</sup> <sup>7</sup> / <sub>16</sub> (36.5)	
CHARACTERISTIC STRENGTH (RESISTANCE) INSTALLED IN NORMAL-WEIGHT CONCRETE <sup>4</sup>				
Resistance at each anchorage point, cracked or uncracked concrete (2,500 psi)	$F_{ra}$	lb (kN)	Number of anchorage points	
			$n_1 \geq 4$	$n_1 \geq 3$
			650 (3.0)	450 (2.0)
Strength reduction factor <sup>3</sup>	$\Phi_{ra}$	-	0.65	

For SI: 1 inch = 25.4 mm; 1 ksi = 6.894 N/mm<sup>2</sup>; 1 lbf = 0.0044 kN

<sup>1</sup> The data in this table is intended to be used with Strength Design provisions of Section 4.3 of this report; loads are independent of direction and may be applied in tension, shear or any combination thereof.

<sup>2</sup> Installation must comply with published installation instructions and this report.

<sup>3</sup> All values of  $\Phi$  were determined from the load combinations of 2024 IBC Section 1605.1 or ACI 318-19 Section 5.3.

<sup>4</sup> Anchors are permitted to be used in lightweight concrete providing the design strength  $\Phi_r F_{ra}$  is multiplied by the modification factor,  $\lambda_a$ , as applicable. See Section 4.1.11 of this report.

<sup>5</sup> For Allowable Stress Design, see Section 4.3.3 of this report.

**TABLE 7— APPLICABLE SECTIONS OF THE IBC UNDER EACH EDITION OF THE IBC**

2024 IBC	2021 IBC	2018 IBC	2015 IBC	2012 IBC
Section 1605.1		Section 1605.2 or 1605.3		
Section 1705.1.1 and Table 1705.3				
Section 1901.3				Sections 1908 and 1909
Sections 1903 and 1905				
Section 1905.7	Section 1905.1.8			Section 1905.1.9

**TABLE 8— APPLICABLE SECTIONS OF ACI 318 UNDER EACH EDITION OF THE IBC**

2024 IBC	2021 IBC	2018 IBC	2015 IBC	2012 IBC
<b>ACI 318-19</b>		<b>ACI 318-14</b>		<b>ACI 318-11</b>
2.3		2.3		D.1
5.3		5.3		9.2
Chapter 17		Chapter 17		Appendix D
17.3.1		17.2.7		D.3.7
17.5.1.2		17.3.1		D.4.1
17.5.3		17.3.3		D.4.3
17.6.1		17.4.1		D.5.1
17.6.1.2		17.4.1.2		D.5.1.2
17.6.2		17.4.2		D.5.2
17.6.2.2		17.4.2.2		D.5.2.2
17.6.2.5.1		17.4.2.6		D.5.2.6
17.6.3.1		17.4.3.1		D.5.3.1
17.6.3.2.1		17.4.3.2		D.5.3.2
17.7.1		17.5.1		D.6.1
Eq. 17.7.1.2b		Eq. 17.5.1.2b		Eq. D-29
17.7.2		17.5.2		D.6.2
17.7.2.2.1		17.5.2.2		D.6.2.2
Eq. 17.7.2.2.1a		Eq. 17.5.2.2a		Eq. D-33
17.7.3		17.5.3		D.6.3
17.8		17.6		D.7
17.9.2		17.7.1 and 17.7.3		D.8.1 and D.8.3
17.9.4		17.7.5		D.8.5
17.9.5		17.7.6		D.8.6

This report remains under an active [continuous compliance program](#) through the end of May 2027.

[www.icc-es.org](http://www.icc-es.org) | (800) 423-6587 | (562) 699-0543

A Subsidiary of the International Code Council®

DIVISION: 03 00 00—CONCRETE

Section: 03 16 00—Concrete Anchors

DIVISION: 05 00 00—METALS

Section: 05 05 19—Post-Installed Concrete Anchors

REPORT HOLDER:

MKT FASTENING, LLC

EVALUATION SUBJECT:

SRS+ ANCHOR IN UNCRACKED CONCRETE AND SRS ANCHOR IN CRACKED AND UNCRACKED CONCRETE (REDUNDANT APPLICATIONS)

## 1.0 REPORT PURPOSE AND SCOPE

### Purpose:

The purpose of this evaluation report supplement is to indicate that the MKT SRS+ Carbon Steel Wedge Anchor in uncracked concrete, and the MKT SRS Stainless Steel Wedge Anchor for redundant applications in cracked and uncracked concrete described in ICC-ES evaluation report [ESR-3782](#), has also been evaluated for compliance with the codes noted below.

### Applicable code editions:

- 2023 Florida Building Code—Building
- 2023 Florida Building Code—Residential

## 2.0 CONCLUSIONS

The MKT SRS+ Carbon Steel Wedge Anchors in uncracked concrete, and the MKT SRS Stainless Steel Wedge Anchors for redundant applications in cracked and uncracked concrete, described in Sections 2.0 through 7.0 of the evaluation report [ESR-3782](#), comply with the *Florida Building Code—Building* and the *Florida Building Code—Residential*. The design requirements must be determined in accordance with the *Florida Building Code—Building* or the *Florida Building Code—Residential*, as applicable. The installation requirements noted in ICC-ES evaluation report [ESR-3782](#) for the 2021 *International Building Code*® meet the requirements of the *Florida Building Code—Building* or the *Florida Building Code—Residential*, as applicable.

Use of the MKT SRS+ Carbon Steel Wedge Anchors in uncracked concrete, and the MKT SRS Stainless Steel Wedge Anchors for redundant applications in cracked and uncracked concrete have also been found to be in compliance with the High-Velocity Hurricane Zone provisions of the *Florida Building Code—Building* and the *Florida Building Code—Residential* with the following condition:

- a) For connections subject to uplift, the connection must be designed for no less than 700 pounds (3114 N) in accordance with item 3 of Section 2321.7 of the *Florida Building Code—Building*.

For products falling under Florida Rule 61G20-3, verification that the report holder's quality-assurance program is audited by a quality-assurance entity approved by the Florida Building Commission for the type of inspections being conducted is the responsibility of an approved validation entity (or the code official, when the report holder does not possess an approval by the Commission). Florida Rule 61G20-3 is applicable to products and/or systems which comprise the building envelope and structural frame for compliance with the structural requirements of the Florida Building Code.

This supplement expires concurrently with the evaluation report, reissued June 2026.